



Effective: September 2009

### Complete System Management and Status Notification Alerts—Remotely access alarm status of network smoke detection devices.

AIR-Intelligence has used the latest object-orientated programming technologies to create the SenseNET™ remote signaling, interrogation and set-up system. The result is a fast reliable and easy to use communications program that has many innovative technologies integrated into its core.

As a PC graphics system SenseNET™ is a Windows® based program that provides central management and monitoring of up to 16 loops, each of up to 127 AIR-Intelligence ASD devices. The SenseNET™ loops are highly fault tolerant and incorporate signal verification and error checking algorithms for the utmost in reliability.

SenseNET™ integrates seamlessly with all AIR-Intelligence detectors and allows for future developments in detection technology.

### PC Graphics

PC/Windows-based graphics system providing an intuitive user interface with advanced communication and diagnostic tools enabling management of multiple networks.

### PC Control Unit

Interfaces the detector RS-485 communications network to RS-232 for connection to a PC serial port.



### Key Features:

- Manages 16 loops of 127 detectors via Command Modules.
- Manages all devices centrally.
- Real-time indication of alarms with definable sound files.
- User definable sound files for alarm and fault conditions.
- Displays maps with specific instructions.
- SiteAudit™ logs all events in real-time.
- SiteScan™ detects all attached devices for rapid configuration.
- SiteMail™ and SitePage™ for automatic email and text alarm alerts.
- Four (4) levels of password protected access.
- Full system diagnostics.
- Connectivity to other manufacturers' systems.
- Global configuration changes.
- Display full system status or historical information at any time.

## Networking

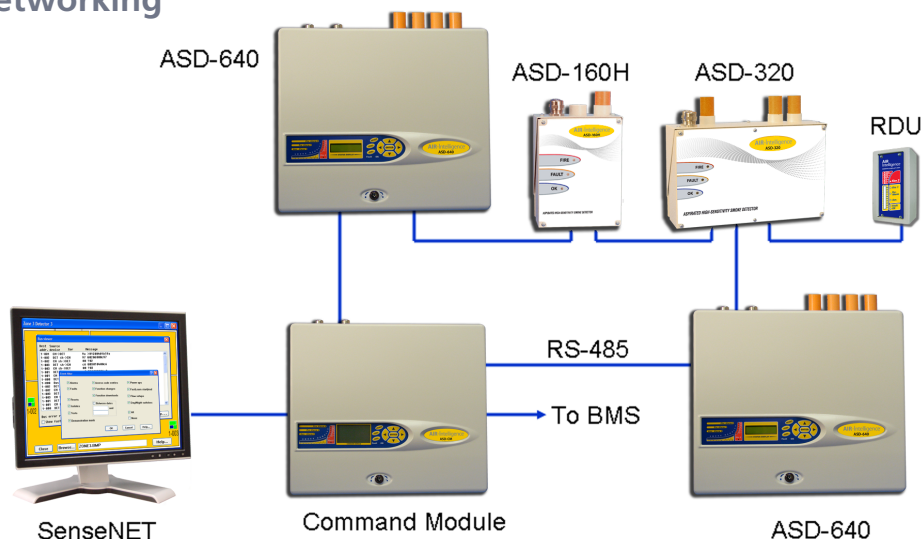

## View ClassiFire® 3D in Real-Time

Confirm correct current device operation with full diagnostics.

## Set Site Maps and Warnings

Display maps and instructions on alarms with definable sound files.

## Device Settings

Streamline configuration changes by managing all devices centrally. SiteScan™ automatically detects all attached devices for rapid configuration.

## History List

SiteAudit™ logs all events to disk in real time. Get historical information at any time.

## Paging

SitePage™ technology sends text messages to GSM telephones or pagers.

## Email

SiteMail™ sends email alert messages as they occur.

## Specifications

PC Interface supply voltage	220V - 240V
Maximum Bus Loop Length	4,000 ft. (1,200 m) between repeater or detector
Cable Type	RS-485 data cable (Belden 9841 or equivalent)
Maximum Number of Devices per Loop	127
Maximum Number of Loops	16
Total Maximum Number of Devices	2032

ClassiFire, LDD 3D3 and SenseNET are trademarks of AirSense Technologies.  
AIR-Intelligence is a trademark of Kidde-Fenwal, Inc.

© 2009 Kidde-Fenwal, Inc.

## Applications

- Aircraft Hangars
- Airport Terminals
- Anti-Smoking Enforcement
- Atria
- Cable Tunnels
- Ceiling Voids & Raised Floors
- Cleanrooms
- Coal Conveyers
- Computer Cabinets
- Computer Rooms
- Corrections Facilities
- Electronic Data Processing (EDP) Centers
- Engine Rooms
- Escalators
- Flour Mills
- Food Preparation Areas
- Freezer Warehouses
- Heritage Buildings
- High-End Residential
- Hospitals
- Hotel Lobbies
- Metro Tunnels
- Museums
- Paper Mills
- Record Storage Facilities
- Recycling Centers
- Semiconductor Fabrication
- Telecommunications Facilities
- Textile Areas
- Tobacco Plants
- Warehouses and Distribution Centers
- Wood Recycling

Kidde Fire Systems  
400 Main Street  
Ashland, MA 01721 USA

Tel.: 508.881.2000  
Fax: 508.881.8920  
www.kiddefiresystems.com

 **Kidde Fire Systems**

A UTC Fire & Security Company

SS AI-010 Rev. AA